



F-Series Radial



**Elmo
Rietschle**
A Gardner Denver Product





F-CEV-S / F-CEV-D



F-CEVF (29)



F-CEVF (31)



F-RER / F-REL

Single and multi-stage radial blowers

Elmo Rietschle offers a wide range of single and multi-stage radial blowers for vacuum and pressure operation.

F-CEV multi-stage radial blowers

These blowers are available for suction (F-CEV-S) and pressure (F-CEV-D) mode and cover a wide range of industrial applications. F-CEVF versions include either a small dust collection canister or a large canister for the collection of plastic or paper trimmings.

F-RER and F-REL single stage radial blowers

These blowers come in a wide variety of sizes and can be used for both suction and pressure mode in many industrial processes where high volume flow at small differential pressures are needed. Variable frequency drives are available.

When it comes to installing these blowers, you will find that any position (left/right/vertical/horizontal) is possible. F-RER blowers are right turning, F-REL left turning for maximum flexibility in cases where space is essential (such as in central air cabinets).

Advantages at a glance

- Cast aluminum housings and impellers
- Reliable, and economic operation
- Greased for life bearings
- Quiet operation
- Process safe (no reverse contamination)
- Variable speed drives available
- Low maintenance



Applications

Air conditioning and ventilation

Environmental engineering

- Aeration
- Drying
- Extraction systems
- Waste water treatment

Industrial applications

- Drying
- Dust extraction
- Vacuum cleaning

Packaging industry

- Extracting film, foil or plastic pieces

Pneumatic conveying

Printing industry

- Air supply cabinets for printing presses
- Air supply cabinets for post-press machines

Textile industry

- Drying
- Dust extraction

Woodworking industry

- Dust extraction

Product overview

F-CEV-S

Radial blowers with three to five stages for vacuum operation

Capacities up to 8.9 m³/min and vacuum up to 115 mbar.
Compact design, low temperature operation even when throttled.
Fast start-up due to light weight impellers.

F-VEC-D

Radial blower with three to five stages for pressure operation

Capacities up to 9.3 m³/min and pressure up to 125 mbar.
Compact design, low temperature operation even when throttled.
Fast start-up due to light weight impellers.

F-CEVF (29)

Multi stage radial blowers for vacuum operation

Capacities up to 5 m³/min. Total pressure difference up to 90 mbar.
Complete with filter and dust separator. Suitable for removing paper powder and dust.

F-CEVF (31)

Multi stage radial blowers for vacuum operation

Capacities up to 7.8 m³/min. Total pressure difference up to 70 mbar.
Complete with high filter vessel and collection bin. Suitable for removing paper, film or plastic pieces.

F-RER / F-REL

Radial blowers for vacuum and pressure operation

Capacities up to 57 m³/min and vacuum up to 95.5 mbar, pressure up to 99.5 mbar. Solid light weight construction.
Vibration free and quiet running. The bearings are greased for life and need no servicing. Maximum installation flexibility.

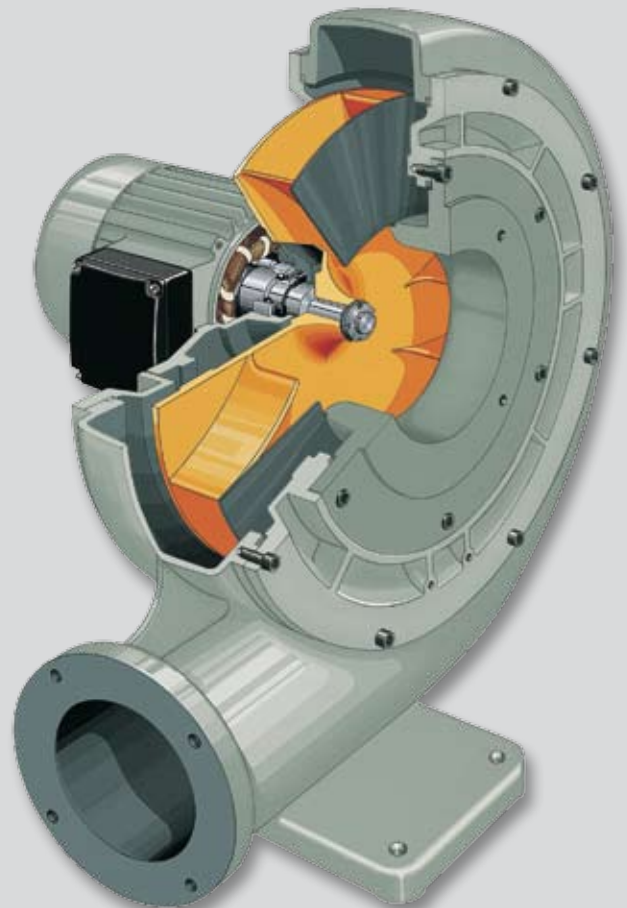

Technical specifications

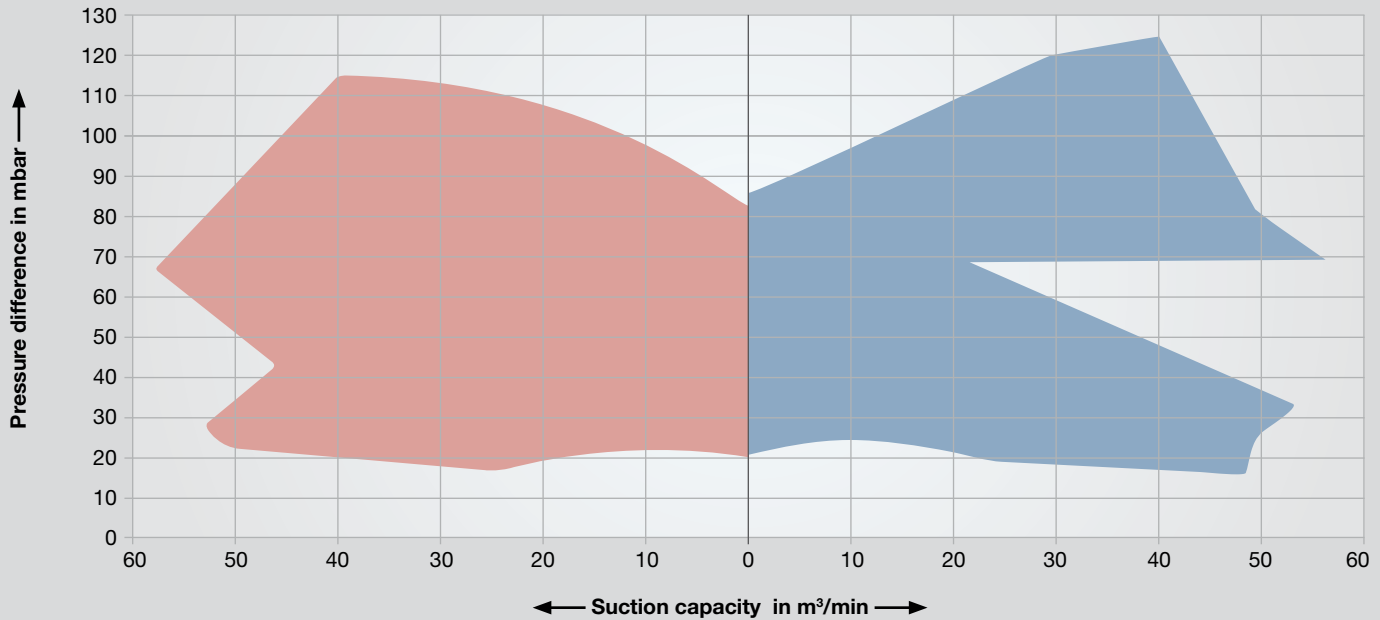

Operating principle

As the impellor rotates, the air in the blade chamber (1) of the impellor (2) is centrifugally moved outward and exits at the edge of the impellor (3). This creates negative pressure at the hub of the impellor (5) causing air to flow in from the inlet port (4).

This incoming air is deflected from an axial into a radial direction as it enters the blade chambers (6). Due to the high speed of the impellor, the air flows outward into the spiral housing (7). At this point the velocity is reduced and part of the energy is transformed into compression energy. The air then exits through the outlet port (8) of the blower.

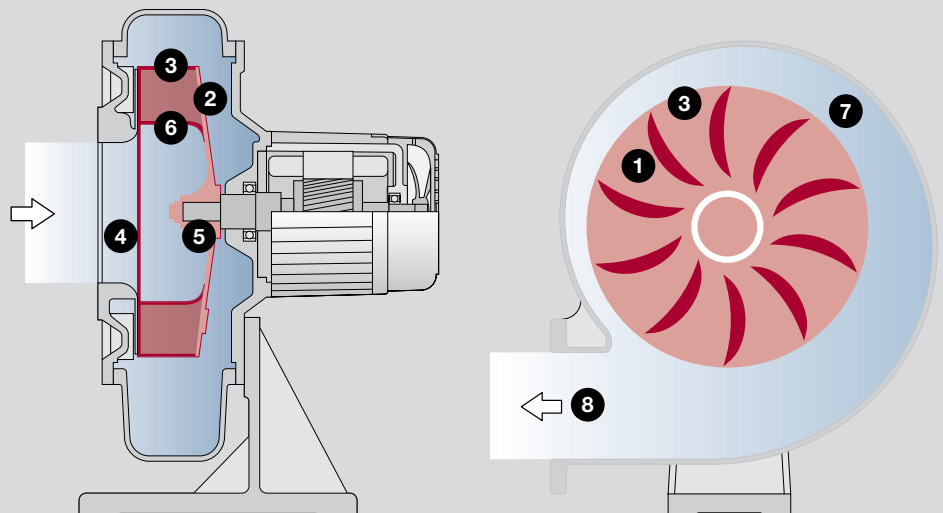



Technologies for all vacuum and pressure applications



F-Series Radial



G-Series Side Channel



L-Series Liquid Ring



V-Series Rotary Vane



R-Series Rotary Lobe



C-Series Claw



S-Series Screw



X-Series Systems

**Gardner
Denver**

Elmo Rietschle is a brand of the
Gardner Denver Blower Division

Representative office:

Kinetic Engineering Co., Ltd.

2 Soi Pracha-u-thit 56, Pracha-u-thit Rd.,

Tungkru, Tungkru, Bangkok 10140 THAILAND

Tel: +66 2 873 5550 (AUTO) Fax: +66 2 873 5552

E-mail: sales@kinetic.co.th www.kinetic.co.th